

Multifunctional, twin column chromatography in a simple, robust design

Features

- Faster processing by up to 3x
- Improved Protein A and buffer utilization by up to 50%
- Simple design to facilitate GMP validation
- Exclusive digital fluid management
- Ability to perform batch, integrated polish and continuous processes
- On-board buffer in-line dilution option
- Space-saving, compact footprint



Successfully qualified in clinical production environments

YMC Contichrom TWIN's two-column configuration facilitates continuous chromatography from process development to large-scale biopharmaceutical production.

This platform of GMP-ready, easy-to-use chromatography systems, offers a wide range of flow and column sizes and can be configured to operate in multiple modes.

Platform models from 0.02 to 20 LPM. From 0.2 to ~125 kg product / dayand more.



YMC Contichrom TWIN CaptureSMB® LPLC

Twin-column capture chromatography that continuously meets your needs, simply.

Leading the continuous processing evolution

The YMC Contichrom TWIN LPLC is an easy-to-use, GMP-ready, multi-column chromatography system that delivers high performance continuous, integrated or batch chromatography processes for development to large-scale biopharmaceutical production. The Contichrom TWIN platform spans a wide range of flow and column sizes and has several options to incorporate multiple functionality on a single unit. The Contichrom TWIN is built on YMC ChromaCon's CaptureSMB patented approach to twin-column purification. Because of the two-column configuration, the Contichrom TWIN is a simple design that facilitates continuous or semi-continuous chromatography implementation. The simple yet robust design reduces risk of costly downtime, and minimizes operating expenses. It is well suited for capture steps using Protein A or IEX separations for most protein purification processes.

One system, multi-function

This advanced system can be configured to operate in multiple modes: batch, integrated polish and continuous chromatography with enhanced buffer in-line dilution (BID). The design accommodates parallel or in-series column configurations for integrated polish using an on-board BID for in-line adjustment of pH, thus eliminating any hold up step.

A buffer, feed and CIP manifold that enables aseptic connection to single use bags is available and allows a closed environment

Contichrom TWIN LPLC delivers

- Faster processing by up to 3x
- Improved Protein A and buffer utilization by up to 50%
- Simple design to facilitate GMP validation
- Exclusive digital fluid management
- Ability to perform batch, integrated polish and continuous processes
- On-board buffer in-line dilution option
- Scale-up/-down from Contichrom® CUBE bench-top instrument
- Space-saving, compact footprint



Fig. 1: YMC Contichrom TWIN LPLC 100 shown with YMC columns

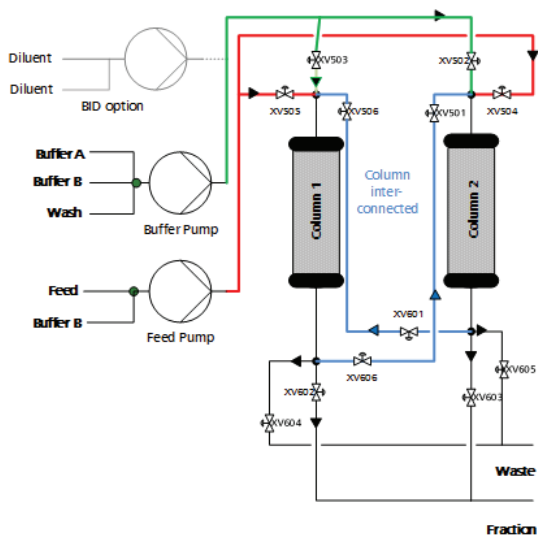

Fig. 2: Contichrom TWIN flow schematic

Increased productivity, quick payback

The flexible functionality of Contichrom TWIN, its precision performance and simple design, enables users to experience increased productivity and buy one unit that does the work of several systems, which translates into an increased ROI compared to other chromatography systems. The multi-functionality of the system increases asset value allowing the use of the same skid for batch, integrated polish and continuous operations.

Advanced Simplicity

The two-column Contichrom TWIN achieves the same productivity improvements as systems with more columns but with significantly less complexity. This accelerates validation, significantly simplifies maintenance, and minimizes costly downtime and operating expenses. In addition, the simple design streamlines implementation in the process development lab or in production because the system is easy to understand and use.

Unique dynamic range

YMC Contichrom TWIN systems have an extraordinary flow range allowing the user to employ a very wide choice of column diameters on the same system (Table 1). One skid can potentially span use as pilot, process development and a production unit.

Table 1. Contichrom TWIN LPLC dynamic range

		Pump Flow Range L/min	System Flow Rate L/min	Column ID cm	Feed L/day	Product kg/day
TWIN 100	Min	0.004	0.02	2.5	47.12	0.21
	Max	0.8	0.8	10	754.0	3.4
TWIN 300	Min	0.02	0.08	5	185.5	0.85
	Max	3.3	3.3	20	3,016	13.6
TWIN 500	Min	0.06	0.24	8	424	1.9
	Max	10	10	45	15,268	68.7
TWIN 1000	Min	0.12	0.48	5	1,696	8.1
	Max	20	20	60	21,143	129

The system flow rate is the recommended flow rate for continuous operation. The above data are projections based on 5 g/L titer and a column linear velocity of 300 cm/h with a 24-hour operation time.

System design and performance

The system is designed to accommodate multiple modes in a single skid; batch, integrated polish, continuous chromatography, and buffer in-line dilution capability (Figure 2). Columns can be configured either in-parallel or in-series. With integrated polish operation, two different modes of chromatography can be run consecutively, for example, ion exchange (IEX) on Column 1 and then hydrophobic interaction chromatography (HIC) on Column 2 with or without buffer adjustment and no hold-up step.

The system's design and performance have been verified on multiple mAb products at several GMP producers in addition to extensive in-house experiments where the system was rigorously tested on buffers continuously over 13 days. Reproducible performance on continuous mAb capture over an extended run is illustrated in Fig. 3.

Scalability from bench to production (both scale-up and scale-down) was verified at multiple customer sites by operating both the Contichrom CUBE bench instrument and Contichrom TWIN 100 simultaneously (see Figs 7, 8 & 9) on multiple mAb products.

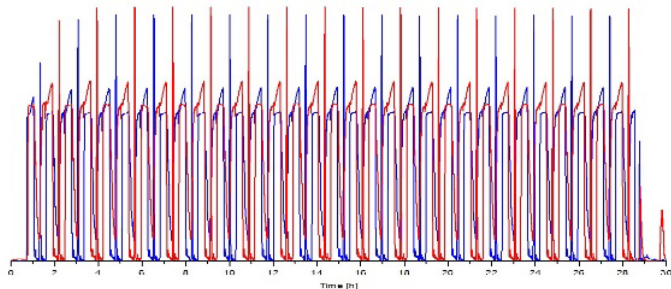

Fig.3: Performance over extended runs (>30 hours) demonstrates high reproducibility and robust design. (Shown UV traces over time.)

Digital control, advanced fluidic design

Designed to meet the demanding requirements of next generation process development, Contichrom TWIN LPLC consists of digitally-controlled, sanitary pumps that provide industry-leading flow precision and accuracy. The triplex pump configuration delivers nearly pulse-free flow. An optimized system flow path and specially designed multi-port valves deliver extremely low hold-up volume for exceptional chromatographic performance that also facilitates cleaning.

Scale up, scale down

A simple tool for scaling-up or down is ChromaCon's Contichrom CUBE instrument (see back page) that can be used to develop new processes or troubleshoot existing ones. The CUBE is a modular, bench-top instrument for performing batch, integrated polish, and continuous chromatography at a smaller scale (flow 0.1 – 36 mL/min or 0.1 – 100 mL/min, up to 50 bar; HPLC versions up to 100 bar). Proven ChromIQ software provides enhanced functionality and visualization for continuous, cyclic processes. YMC and ChromaCon teams have worked hand-in-hand in the development of Contichrom TWIN software for continuity with the ChromIQ software.

Robust design for reliable operations

Contichrom TWIN systems incorporate comprehensive safety features, such as a two-level alarm monitor: one level to give a warning message and the other to give a critical alarm to enable immediate suspension of the chromatography process. Industrially designed for manufacturing environments with a manual Emergency Stop and Master Reset buttons, the system embodies YMC's uncompromising commitment to safety.

Typical applications

Contichrom TWIN is used in process development, pilot labs and production for continuous, batch, and integrated polish process development and small production runs. Contichrom TWIN, with its wide dynamic range, is ideally suited for multi-product environments. The small footprint enables installation in space-constrained facilities.

Application examples

- Monoclonal antibody, mAb fragment, and antibody drug conjugate purification
- Virus and recombinant protein purification
- mAb isoform profile tuning
- Fc fusion protein purification
- Plasma fractionation and purification of plasma proteins
- Purification of PEGylated proteins
- Debottlenecking fed-batch processes where the upstream has surpassed the downstream productivity



Fig. 4: Scale up / scale down is seamless with Contichrom CUBE (shown left)

Software

An information-rich, graphical interface displays system and process information as well as historical trends (Historian) putting relevant information in one place enabling informed decision-making (Figure 5). The main process screen can also be used to manually operate the system to facilitate qualification and troubleshooting.

Quality and regulatory considerations

As with all YMC bioprocess equipment, the Contichrom TWIN LPLC system is designed to meet high quality expectations. The design and construction of the equipment meets the following standards, assuring a safe, ergonomic system capable of producing the product within the guidelines of the FDA:

- System designed for GMP operation and validation
- Audit trail to support 21 CFR part 11 compliance and performer / verifier traceability for GMP operations and compliance
- USP Class VI materials and seals
- Compliance to ASME-BPE
- Hygienic metering pumps
- CE conformity

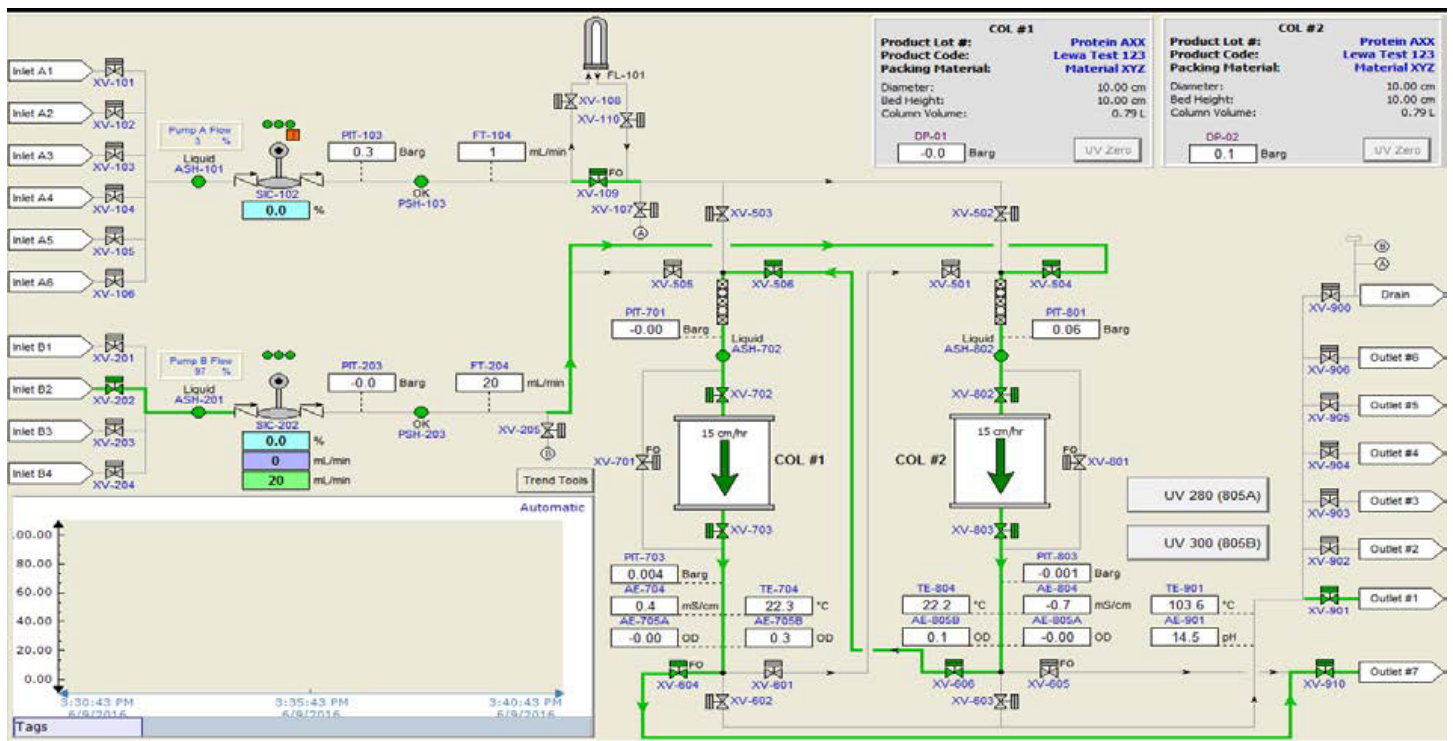

Fig 5. HMI Process flow chart and main navigation screen for monitoring and controlling the system.

The Contichrom TWIN LPLC system uses PLC or DeltaV software to control the chromatography process, to acquire data and to provide historical trending. The software provides user configurable control of all chromatographic parameters. The user adaptable software enables 21 CFR Part 11 compliance and is built on Rockwell FactoryTalk® View SE or Emerson DeltaV. The system provides recipe management (Figure 6) with access control to prevent modification of a recipe by unauthorized users, as well as providing an audit trail for recipe modification. Batch reports are easily generated.

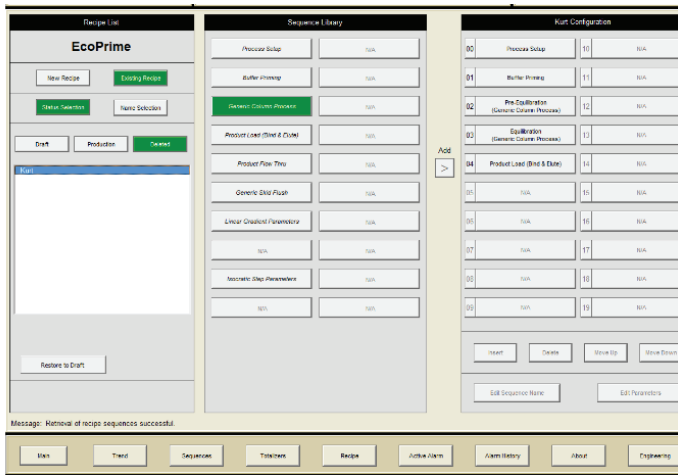

Fig 6. Contichrom TWIN LPLC Recipe configuration screen

The software generates system documentation such as an Alarm Table and I/O and Interlock lists to facilitate qualification. There is built-in audit and event tracking to support validation.

User performance

Users who have run the Contichrom TWIN LPLC on their drug substances have proven the claims of an increase in productivity and reduction in buffer consumption. (Fig. 7, 8, 9). Scale up from Contichrom CUBE to the Contichrom TWIN at over 100X has been verified and published. (Ref. Scale-Up of Twin-Column Periodic Countercurrent Chromatography for mAb Purification by James Angelo et al. BioProcess International April 2018.)

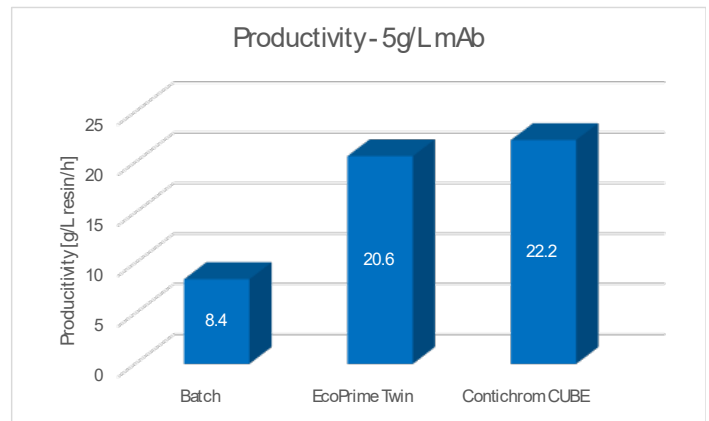

Fig 7. Comparison of conventional batch vs. Contichrom TWIN 100 and Contichrom CUBE shows over 2x productivity and nearly identical performance on the bench unit (CUBE) and production scale unit (TWIN).

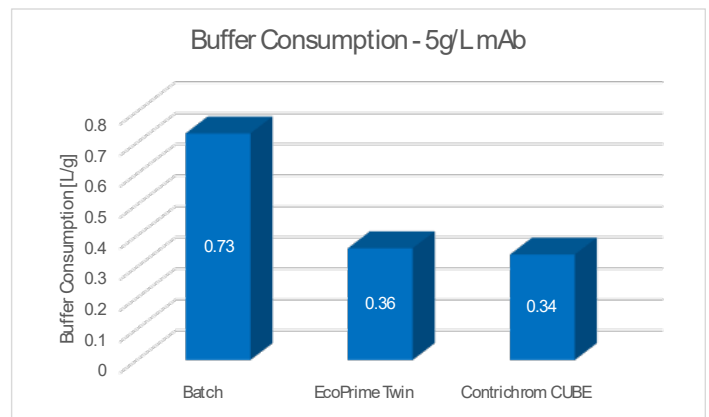

Fig 8. Comparison of conventional batch vs Contichrom TWIN 100 and Contichrom CUBE 50% savings in buffer and nearly identical results between the bench unit (CUBE) and production scale Contichrom TWIN indicates seamless scale-up.

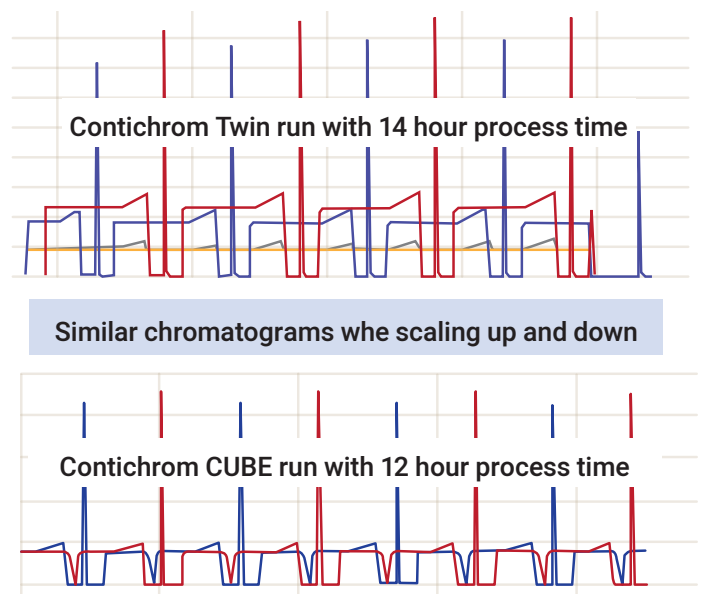
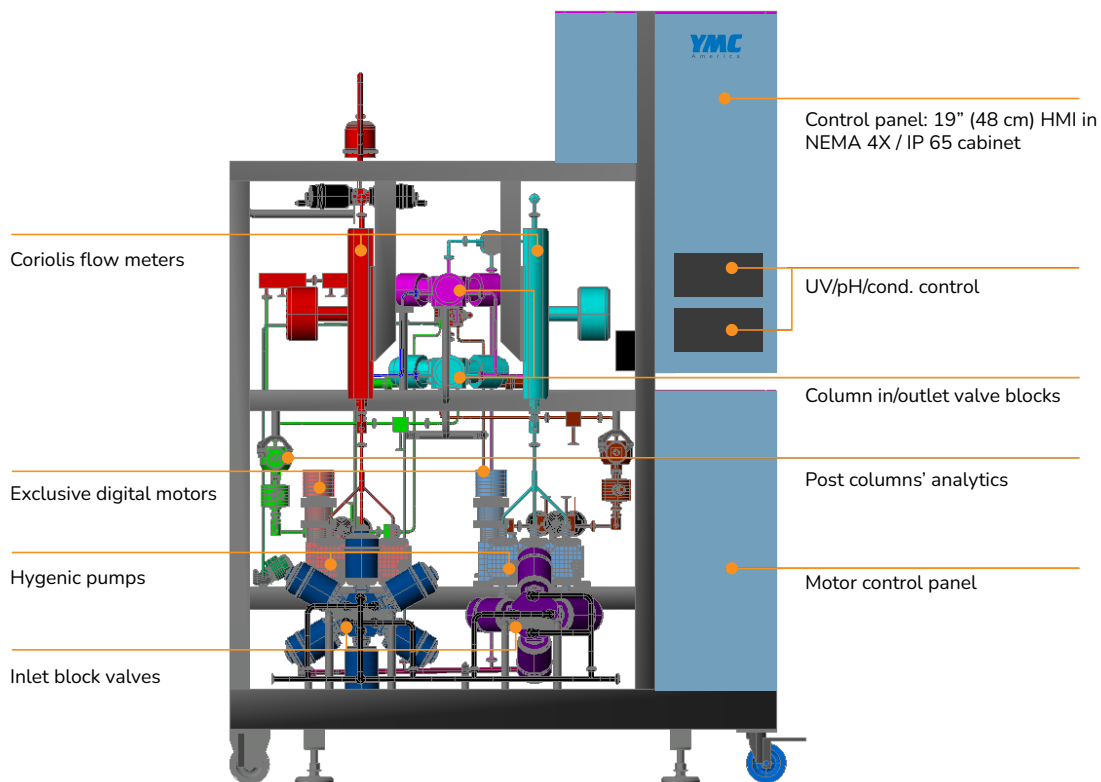

Fig 9. Steady state can be reached after only one cycle. Variability of the peak area is less than 1% demonstrating the highly accurate scalability between the bench and production scale unit.



System Specifications

UV absorbance	280 nm and 303 nm
pH range	0 – 13
Conductivity range	0 – 200 mS/cm
Enclosure protection class	UL Type 4x/IP 65
Materials of construction	316L stainless steel

System	Pump flow rate *
Contichrom TWIN 100	0.004 – 0.8 LPM
Contichrom TWIN 300	0.02 – 3.3 LPM
Contichrom TWIN 500	0.06 – 10.0 LPM
Contichrom TWIN 1000	0.12 – 20.0 LPM

Skid size (LxWxH)

Contichrom TWIN 100	145 x 87 x 200 cm
Contichrom TWIN 300	183 x 89 x 200 cm
Contichrom TWIN 500	231 x 112 x 200 cm
Contichrom TWIN 1000	270 x 150 x 200 cm

Skid weight (approx.)

Contichrom TWIN 100	430 kg
Contichrom TWIN 300	612 kg
Contichrom TWIN 500	800 kg
Contichrom TWIN 1000	1000 kg

Model	System Capability
TWIN	TWIN with CaptureSMB plus batch capability; user can perform step and linear gradients
TWIN Plus BID and Integrated	TWIN, Batch, buffer in-line dilution (BID) and capability for Integrated Polish
Both models include AutomAb dynamic process control for keeping the CaptureSMB process at an optimum	

Operating Pressure and Temperature

Maximum operating pressure	7.5 bar
Ambient temperature range	4 – 25 °C
Process temperature range	4 – 40 °C

*Slightly higher low-end flow for continuous operation. Reference Table 1.

It starts here –

the Contichrom CUBE

This is our flagship FPLC bench-top system. It offers unique capabilities for mastering complex separation challenges by using our proprietary processes. The user-friendly software automates the use of these processes.

- Standard batch processes
- Automated two-step batch processes with in-line dilution
- Automated processes for continuous capture (CaptureSMB)
- AutomAb dynamic process control for keeping the CaptureSMB process at an optimum
- Automated cyclic polishing process (MCSGP with AutoPeak) for difficult separation challenges
- MControl dynamic process control for keeping the MCSGP with AutoPeak process at an optimum
- Automated cyclic enrichment process (N-Rich) allowing to enrich and isolate product-related impurities
- Various accessories available

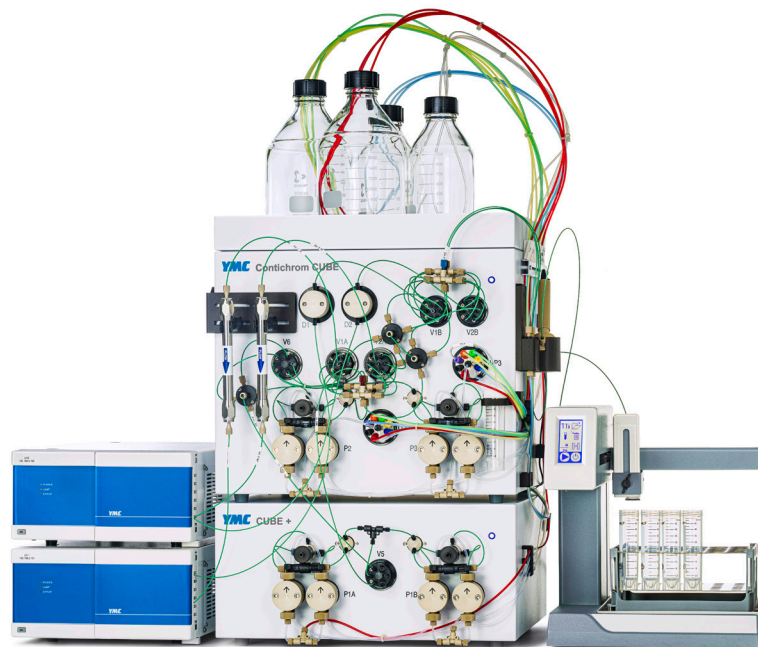

The future provides broader solutions for our customers

YMC America has expanded from the core chromatography bulk media and columns technology business to include the

manufacture of leading laboratory (Contichrom CUBE) and GMP scale prep systems (Contichrom TWIN HPLC and LPLC), as well as other downstream process unit technologies. The group operates two Insight Center laboratories for the support of its products and contract services.

ChromaCon, Contichrom, CaptureSMB, MControl, N-Rich, AutomAb, Flow-2, ChromIQ are registered trademarks of YMC ChromaCon AG. Content is subject to change without notice.